

रोल नं. 

--	--	--	--	--	--	--

  
Roll No.

परीक्षार्थी कोड को उत्तर-पुस्तिका के मुख-पृष्ठ पर अवश्य लिखें।

Candidates must write the Code on the title page of the answer-book.

- कृपया जाँच कर लें कि इस प्रश्न-पत्र में मुद्रित पृष्ठ 16 हैं।
- प्रश्न-पत्र में दाहिने हाथ की ओर दिए गए कोड नम्बर को छात्र उत्तर-पुस्तिका के मुख-पृष्ठ पर लिखें।
- कृपया जाँच कर लें कि इस प्रश्न-पत्र में 26 प्रश्न हैं।
- कृपया प्रश्न का उत्तर लिखना शुरू करने से पहले, प्रश्न का क्रमांक अवश्य लिखें।
- इस प्रश्न-पत्र को पढ़ने के लिए 15 मिनट का समय दिया गया है। प्रश्न-पत्र का वितरण पूर्वाह्न में 10.15 बजे किया जाएगा। 10.15 बजे से 10.30 बजे तक छात्र केवल प्रश्न-पत्र को पढ़ेंगे और इस अवधि के दौरान वे उत्तर-पुस्तिका पर कोई उत्तर नहीं लिखेंगे।
- Please check that this question paper contains 16 printed pages.
- Code number given on the right hand side of the question paper should be written on the title page of the answer-book by the candidate.
- Please check that this question paper contains 26 questions.
- **Please write down the Serial Number of the question before attempting it.**
- 15 minute time has been allotted to read this question paper. The question paper will be distributed at 10.15 a.m. From 10.15 a.m. to 10.30 a.m., the students will read the question paper only and will not write any answer on the answer-book during this period.

## भौतिक विज्ञान (सैद्धान्तिक)

## PHYSICS (Theory)

निर्धारित समय : 3 घण्टे

अधिकतम अंक : 70

Time allowed : 3 hours

Maximum Marks : 70

55/1/P

1

P.T.O.



### सामान्य निर्देश :

- (i) सभी प्रश्न अनिवार्य हैं। इस प्रश्न-पत्र में कुल 26 प्रश्न हैं।
- (ii) इस प्रश्न-पत्र के 5 भाग हैं : खण्ड अ, खण्ड ब, खण्ड स, खण्ड द और खण्ड य।
- (iii) खण्ड अ में 5 प्रश्न हैं, प्रत्येक का 1 अंक है। खण्ड ब में 5 प्रश्न हैं, प्रत्येक के 2 अंक हैं। खण्ड स में 12 प्रश्न हैं, प्रत्येक के 3 अंक हैं। खण्ड द में 4 अंक का एक मूल्याधारित प्रश्न है और खण्ड य में 3 प्रश्न हैं, प्रत्येक के 5 अंक हैं।
- (iv) प्रश्न-पत्र में समग्र पर कोई विकल्प नहीं है। तथापि, दो अंकों वाले एक प्रश्न में, तीन अंकों वाले एक प्रश्न में और पाँच अंकों वाले तीनों प्रश्नों में आन्तरिक चयन प्रदान किया गया है। ऐसे प्रश्नों में आपको दिए गए चयन में से केवल एक प्रश्न ही करना है।
- (v) जहाँ आवश्यक हो आप निम्नलिखित भौतिक नियतांकों के मानों का उपयोग कर सकते हैं :

$$c = 3 \times 10^8 \text{ m/s}$$

$$h = 6.63 \times 10^{-34} \text{ Js}$$

$$e = 1.6 \times 10^{-19} \text{ C}$$

$$\mu_0 = 4\pi \times 10^{-7} \text{ T m A}^{-1}$$

$$\epsilon_0 = 8.854 \times 10^{-12} \text{ C}^2 \text{ N}^{-1} \text{ m}^{-2}$$

$$\frac{1}{4\pi\epsilon_0} = 9 \times 10^9 \text{ N m}^2 \text{ C}^{-2}$$

$$m_e = 9.1 \times 10^{-31} \text{ kg}$$

$$\text{न्यूट्रॉन का द्रव्यमान} = 1.675 \times 10^{-27} \text{ kg}$$

$$\text{प्रोटॉन का द्रव्यमान} = 1.673 \times 10^{-27} \text{ kg}$$

$$\text{आवोगाद्रो संख्या} = 6.023 \times 10^{23} \text{ प्रति ग्राम मोल}$$

$$\text{बोल्ट्ज़मान नियतांक} = 1.38 \times 10^{-23} \text{ JK}^{-1}$$



### **General Instructions :**

- (i) **All** questions are compulsory. There are **26** questions in all.
- (ii) This question paper has **five** sections : Section A, Section B, Section C, Section D and Section E.
- (iii) Section A contains **five** questions of **one** mark each, Section B contains **five** questions of **two** marks each, Section C contains **twelve** questions of **three** marks each, Section D contains one value based question of **four** marks and Section E contains **three** questions of **five** marks each.
- (iv) There is no overall choice. However, an internal choice has been provided in one question of two marks, one question of three marks and all the three questions of five marks weightage. You have to attempt only one of the choices in such questions.
- (v) You may use the following values of physical constants wherever necessary :

$$c = 3 \times 10^8 \text{ m/s}$$

$$h = 6.63 \times 10^{-34} \text{ Js}$$

$$e = 1.6 \times 10^{-19} \text{ C}$$

$$\mu_0 = 4\pi \times 10^{-7} \text{ T m A}^{-1}$$

$$\epsilon_0 = 8.854 \times 10^{-12} \text{ C}^2 \text{ N}^{-1} \text{ m}^{-2}$$

$$\frac{1}{4\pi\epsilon_0} = 9 \times 10^9 \text{ N m}^2 \text{ C}^{-2}$$

$$m_e = 9.1 \times 10^{-31} \text{ kg}$$

$$\text{Mass of neutron} = 1.675 \times 10^{-27} \text{ kg}$$

$$\text{Mass of proton} = 1.673 \times 10^{-27} \text{ kg}$$

$$\text{Avogadro's number} = 6.023 \times 10^{23} \text{ per gram mole}$$

$$\text{Boltzmann constant} = 1.38 \times 10^{-23} \text{ JK}^{-1}$$



खण्ड अ

SECTION A

1. किसी सेल के विद्युत्-वाहक बल (ई.एम.एफ.) तथा टर्मिनल वोल्टता के बीच अन्तर (भेद) लिखिए ।

1

Distinguish between emf and terminal voltage of a cell.

2. किसी बिन्दु ऋणात्मक आवेश की क्षेत्र रेखाएँ यहाँ चित्र में दर्शाए गए अनुसार हैं । क्या किसी अल्प ऋणात्मक आवेश के B से A तक जाने में उसकी गतिज ऊर्जा का मान बढ़ेगा या कम होगा ?

1

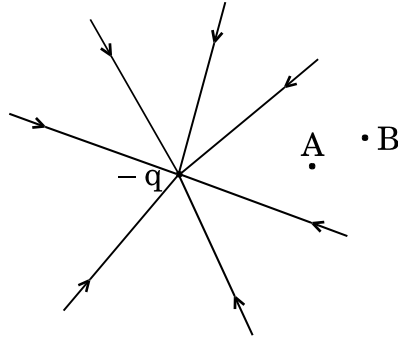

The field lines of a negative point charge are as shown in the figure. Does the kinetic energy of a small negative charge increase or decrease in going from B to A ?

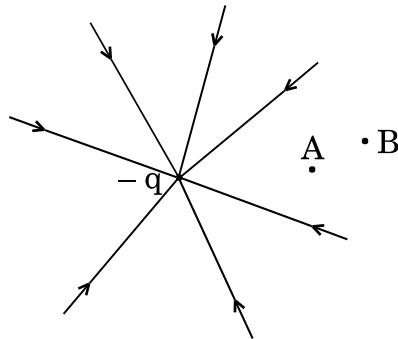

3. संचार व्यवस्था में प्रयुक्त 'पुनरावर्तक (रिपीटर)' का क्या प्रकार्य है ?

1

What is the function of a 'Repeater' used in communication system ?



4. यहाँ दर्शाए गए किरण आरेख में रेखा AB, एक लेंस को निरूपित करती है। बताइए यह लेंस उत्तल है या अवतल।

1

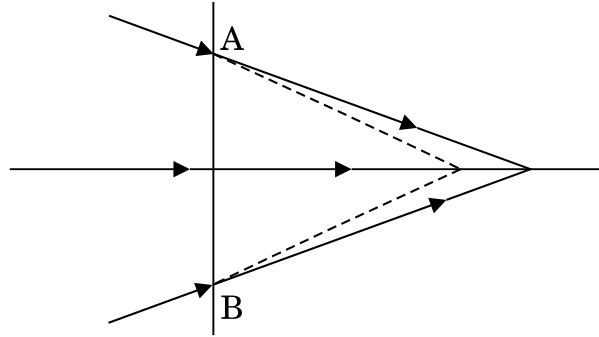

The line AB in the ray diagram represents a lens. State whether the lens is convex or concave.

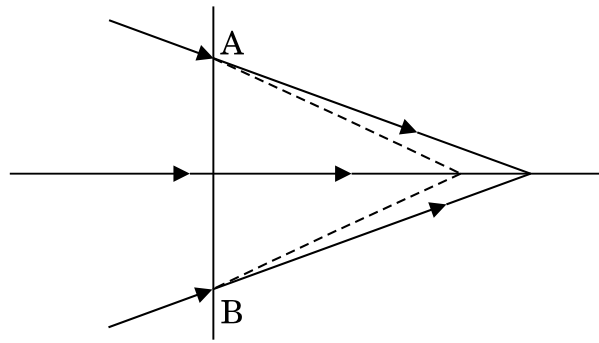

5. किसी ए.सी. (a.c.) परिपथ में आवृत्ति के साथ धारिता-प्रतिघात के परिवर्तन (विचलन) को दर्शाने के लिए एक ग्राफ बनाइए।

1

Draw a graph to show variation of capacitive-reactance with frequency in an a.c. circuit.

खण्ड ब

### SECTION B

6. चित्र में दर्शाए गए मीटर सेतु में, संतुलन बिन्दु सिरे A से 40 cm दूरी पर प्राप्त होता है। यदि R के साथ श्रेणीक्रम में  $10 \Omega$  का प्रतिरोध जोड़ने पर संतुलन बिन्दु A से 60 cm दूरी पर प्राप्त होता है, तो R तथा S के मान का परिकलन कीजिए।

2

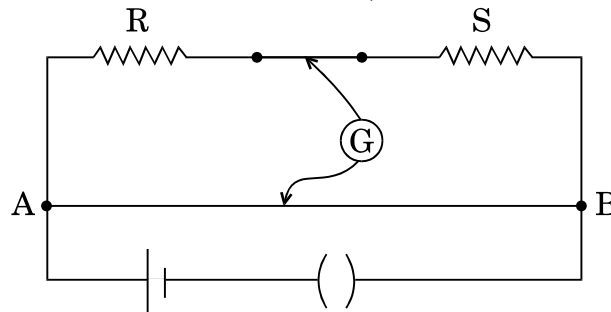

In a meter bridge shown in the figure, the balance point is found to be 40 cm from end A. If a resistance of  $10\ \Omega$  is connected in series with R, balance point is obtained 60 cm from A. Calculate the values of R and S.

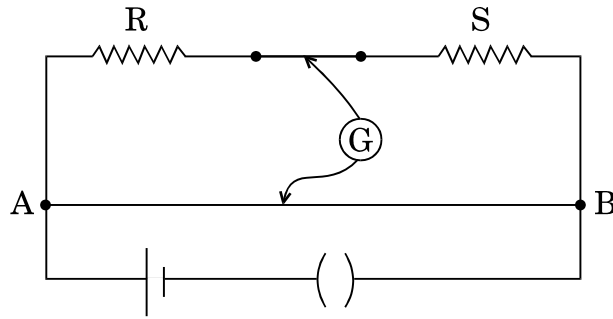

7. काँच के समबाहु त्रिकोणीय प्रिज़्म से प्रकाश की एक किरण इस प्रकार गुज़रती है कि आपतन कोण का मान निर्गत कोण के मान के बराबर है तथा प्रत्येक कोण का मान प्रिज़्म के कोण का  $3/4$  है। विचलन कोण का मान ज्ञात कीजिए।

2

अथवा

उस माध्यम में प्रकाश की चाल का परिकलन कीजिए जिसके लिए क्रांतिक कोण का मान  $45^\circ$  है।

क्या दिए गए दो माध्यमों के एक युग्म के लिए क्रांतिक कोण का मान आपतित प्रकाश की तरंगदैर्घ्य पर निर्भर करता है? कारण बताइए।

2

A ray of light passes through an equilateral glass prism such that the angle of incidence is equal to the angle of emergence and each of these angles is equal to  $3/4$  of angle of prism. Find the angle of deviation.

OR

Calculate the speed of light in a medium whose critical angle is  $45^\circ$ .

Does critical angle for a given pair of media depend on the wavelength of incident light? Give reason.

8. दे ब्रॉग्ली की परिकल्पना के आधार पर, कक्षीय कोणीय संवेग के क्वान्टीकरण सम्बन्धी बोर के दूसरे अभिगृहीत की व्याख्या कैसे की जा सकती है?

2

How does one explain, using de Broglie hypothesis, Bohr's second postulate of quantization of orbital angular momentum?

9. पृष्ठीय (भू) तरंग संचरण से क्या तात्पर्य है? स्पष्ट कीजिए कि उच्च आवृत्तियों के उपयोग द्वारा इस विधि का उपयोग लम्बी दूरी तक संचरण के लिए क्यों नहीं हो सकता।

2

What is ground wave communication? Explain why this mode cannot be used for long distance communication using high frequencies.



10. किसी गतिमान इलेक्ट्रॉन की तुल्य तरंगदैर्घ्य का मान,  $6 \times 10^{-17}$  J ऊर्जा वाले फ़ोटॉन की तरंगदैर्घ्य के बराबर है। इलेक्ट्रॉन के संवेग का परिकलन कीजिए।

2

The equivalent wavelength of a moving electron has the same value as that of a photon of energy  $6 \times 10^{-17}$  J. Calculate the momentum of the electron.

खण्ड स

### SECTION C

11. आरेख में दर्शाए गए परिपथ (जाल) की तुल्य धारिता का मान ज्ञात कीजिए, जबकि प्रत्येक संधारित्र की धारिता  $1 \mu\text{F}$  है। जब X तथा Y सिरों के बीच 6 V की एक बैटरी जोड़ दी जाए, तो इस परिपथ (i) पर आवेश तथा (ii) में संचित ऊर्जा का मान ज्ञात कीजिए।

3

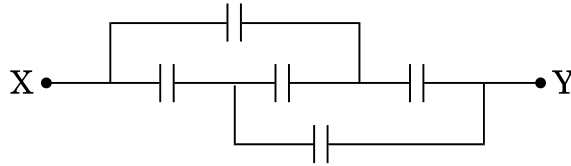

Find the equivalent capacitance of the network shown in the figure, when each capacitor is of  $1 \mu\text{F}$ . When the ends X and Y are connected to a 6 V battery, find out (i) the charge and (ii) the energy stored in the network.

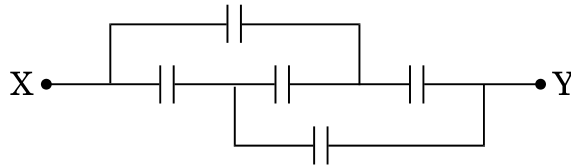

12. उल्लेख कीजिए कि विभवमापी (पोटेंशियोमीटर) किस सिद्धान्त पर आधारित है। ऐसे दो कारक लिखिए जिनसे किसी विभवमापी (पोटेंशियोमीटर) की धारा सुग्राहिता में वृद्धि की जा सकती है। किसी सेल के विद्युत्-वाहक बल (ई.एम.एफ.) को मापने के लिए, वोल्टमीटर की तुलना में विभवमापी (पोटेंशियोमीटर) को वरीयता क्यों दी जाती है ?

3

State the underlying principle of a potentiometer. Write two factors by which current sensitivity of a potentiometer can be increased. Why is a potentiometer preferred over a voltmeter for measuring the emf of a cell ?



13. (a) प्रकाश के फ़ोटॉन चित्रण के पदों में 'विकिरणों की तीव्रता' पद को परिभाषित कीजिए ।
- (b) एकवर्णी प्रकाश की दो किरण पुंजों में एक लाल रंग की और दूसरी नीले रंग की है । इन दोनों की तीव्रता समान है । इनमें से किसमें (i) प्रति एकांक क्षेत्रफल प्रति सेकण्ड फ़ोटॉनों की संख्या अधिक है, (ii) प्रकाश-इलेक्ट्रॉनों की अधिकतम गतिज ऊर्जा का मान अधिक है ? अपने उत्तर की पुष्टि के लिए कारण लिखिए ।

3

- (a) Define the term 'intensity of radiation' in terms of photon picture of light.
- (b) Two monochromatic beams, one red and the other blue, have the same intensity. In which case (i) the number of photons per unit area per second is larger, (ii) the maximum kinetic energy of the photoelectrons is more ? Justify your answer.

14. (a) अपवर्ती दूरदर्शकों की तुलना में परावर्ती दूरदर्शकों को अधिक अच्छा क्यों माना जाता है ? दो कारण लिखकर स्पष्ट कीजिए ।

- (b) दर्पण समीकरण के उपयोग द्वारा दर्शाइए कि उत्तल दर्पण से सदैव आभासी प्रतिबिम्ब ही बनता है, चाहे वस्तु उसके सामने कहीं पर भी स्थित हो ।

3

- (a) Give two reasons to explain why reflecting telescopes are preferred over refracting type.

- (b) Use mirror equation to show that convex mirror always produces a virtual image independent of the location of the object.

15. लेंज़ के नियम को लिखिए तथा एक उदाहरण से दर्शाइए कि यह नियम परिवर्ती चुम्बकीय फ्लक्स की उपस्थिति में, किसी पाश में प्रेरित विद्युत् धारा की दिशा का पूर्वानुमान करने में किस प्रकार सहायक होता है ।

किसी दी गई कुंडली का स्व-प्रेरकत्व 5 mH है । इसमें प्रवाहित विद्युत् धारा का मान 30 ms में 4 A से 1 A हो जाता है । इस कुंडली में प्रेरित विद्युत्-वाहक बल (ई.एम.एफ.) का मान परिकलित कीजिए ।

3

### अथवा

चुम्बकत्व के लिए गाउस का नियम, स्थिर-विद्युतिकी में प्रयुक्त गाउस नियम से किस प्रकार भिन्न है ? संक्षेप में स्पष्ट कीजिए ।

भूमध्यरेखा (विषुवत्-रेखा) पर पृथ्वी का चुम्बकीय क्षेत्र लगभग 0.4 G है । पृथ्वी का चुम्बकीय द्विध्रुव आघूर्ण ज्ञात कीजिए । दिया गया है : पृथ्वी की त्रिज्या = 6400 km.

3





State Lenz's law. Illustrate, by giving an example, how this law helps in predicting the direction of the current in a loop in the presence of a changing magnetic flux.

In a given coil of self-inductance of 5 mH, current changes from 4 A to 1 A in 30 ms. Calculate the emf induced in the coil.

**OR**

In what way is Gauss's law in magnetism different from that used in electrostatics? Explain briefly.

The Earth's magnetic field at the Equator is approximately 0.4 G. Estimate the Earth's magnetic dipole moment. Given : Radius of the Earth = 6400 km.

16. विद्युत्-चुम्बकीय तरंगें कैसे उत्पन्न होती हैं ? इन तरंगों की ऊर्जा का स्रोत क्या है ?  
+ x-अक्ष के अनुदिश गमन (संचरण) करती हुई विद्युत्-चुम्बकीय तरंगों का एक व्यवस्था-चित्र बनाइए । विद्युत् तथा चुम्बकीय क्षेत्रों की दिशा दर्शाइए । विद्युत् तथा चुम्बकीय क्षेत्र के परिमाणों (मानों) तथा संचरण के वेग के बीच सम्बन्ध को लिखिए ।

3

How are electromagnetic waves produced? What is the source of energy of these waves?

Draw a schematic sketch of the electromagnetic waves propagating along the + x-axis. Indicate the directions of the electric and magnetic fields. Write the relation between the velocity of propagation and the magnitudes of electric and magnetic fields.

17. किसी रेडियोऐक्टिव नमूने के क्षय-नियतांक तथा उसकी अर्ध आयु में सम्बन्ध प्राप्त कीजिए ।  
किसी रेडियोऐक्टिव पदार्थ की अर्ध आयु,  $\alpha$ -क्षय में, 100 दिन है । कितने समय के पश्चात्, इस पदार्थ का अविघटित भाग उसके प्रारम्भिक मान का 6.25% होगा ?

3

Obtain the relation between the decay constant and half life of a radioactive sample.

The half life of a certain radioactive material against  $\alpha$ -decay is 100 days. After how much time, will the undecayed fraction of the material be 6.25%?

18. ज़ेनर डायोड के संविरचन (बनाने) में प्रयुक्त किन दो प्रमुख बातों का ध्यान रखा जाता है ?  
ज़ेनर डायोड के वोल्टता नियंत्रक के रूप में उपयोग के सिद्धान्त व उसकी कार्यविधि को एक परिपथ आरेख की सहायता से स्पष्ट कीजिए ।

3

Write two important considerations used while fabricating a Zener diode. Explain, with the help of a circuit diagram, the principle and working of a Zener diode as voltage regulator.



19. चालक, अर्धचालक तथा विद्युत्रोधी पदार्थों में अन्तर दर्शाने के लिए आवश्यक ऊर्जा बैंड आरेख बनाइए ।  
ताप में परिवर्तन से इन पदार्थों के व्यवहार पर क्या प्रभाव होता है ? संक्षेप में स्पष्ट कीजिए । 3  
Draw the necessary energy band diagrams to distinguish between conductors, semiconductors and insulators.  
How does the change in temperature affect the behaviour of these materials ? Explain briefly.
20. (a) संचार व्यवस्था में तीन मूल अवयव कौन-से हैं ? प्रत्येक के प्रकार्य (फंक्शन) को संक्षेप में लिखिए ।  
(b) संचार व्यवस्था में प्रयुक्त इंटरनेट के किन्हीं तीन अनुप्रयोगों का उल्लेख कीजिए । 3  
(a) What are the three basic units in communication systems ? Write briefly the function of each of these.  
(b) Write any three applications of the internet used in communication systems.
21. (a) प्रतिपालित व्यतिकरण फ्रिंजें प्राप्त करने के लिए आवश्यक शर्तें (प्रतिबन्ध) लिखिए ।  
(b) यंग के द्वि-झिरी प्रयोग में, झिरियों के समतल से पर्दे के बीच की दूरी के साथ फ्रिंजों की चौड़ाई के परिवर्तन (विचलन) को दर्शाने के लिए एक ग्राफ बनाइए, जबकि अन्य सभी प्राचल (पैरामीटर्स) अपरिवर्तित रहते हैं । इस वक्र की प्रवणता से क्या सूचना प्राप्त हो सकती है ?  
(c) फ्रिंजों की चौड़ाई पर क्या प्रभाव होगा, यदि झिरियों के बीच की दूरी कम कर दी जाए जबकि अन्य सभी प्राचल (पैरामीटर्स) अपरिवर्तित रहते हैं ? 3  
(a) Write the necessary conditions to obtain sustained interference fringes.  
(b) In Young's double slit experiment, plot a graph showing the variation of fringe width versus the distance of the screen from the plane of the slits keeping other parameters same. What information can one obtain from the slope of the curve ?  
(c) What is the effect on the fringe width if the distance between the slits is reduced keeping other parameters same ?



22. एक श्रेणी एल.सी.आर. (LCR) परिपथ को किसी ऐसे ए.सी. (a.c.) स्रोत के सिरों से जोड़ा जाता है जिसकी परिवर्तनीय कोणीय आवृत्ति ' $\omega$ ' है। दो प्रतिरोधों  $R_1$  तथा  $R_2$  ( $R_1 > R_2$ ) के लिए, ' $\omega$ ' के फलन के रूप में विद्युत् धारा ' $i$ ' के विचलन (परिवर्तन) को दर्शाने के लिए एक ग्राफ बनाइए।

इस ग्राफ (आलेख) के उपयोग से निम्नलिखित प्रश्नों के उत्तर दीजिए :

- (a) किस दशा में अनुनाद अधिक तीक्ष्ण है और क्यों ?  
(b) किस स्थिति में शक्ति क्षय अधिक है और क्यों ?

3

A series LCR circuit is connected across an a.c. source of variable angular frequency ' $\omega$ '. Plot a graph showing variation of current ' $i$ ' as a function of ' $\omega$ ' for two resistances  $R_1$  and  $R_2$  ( $R_1 > R_2$ ).

Answer the following questions using this graph :

- (a) In which case is the resonance sharper and why ?  
(b) In which case is the power dissipation more and why ?

### खण्ड द

### SECTION D

23. एक दिन तूफान के कारण एक गली में विद्युत्-संचरण लाइन का 'गर्म' तार खम्बे से टूट कर नीचे गिर गया। उसके पास से जाते हुए कुछ बालकों ने इसे देखा और उसे उठाकर गली के किनारे रखना चाहा। जैसे ही वे तार (केबल) को छूने जा रहे थे, अनुज ने उन्हें देख लिया और तुरन्त उन्हें धकेल कर दूर हटा दिया, ताकि वे गर्म तार को छू न सकें। धकेले जाने से उनमें से कुछ को चोट लग गई। अनुज उन्हें इलाज के लिए डॉक्टर के पास ले गया।

उपर्युक्त पैराग्राफ पर आधारित निम्नलिखित प्रश्नों के उत्तर दीजिए :

4

- (a) इस घटना के दौरान अनुज द्वारा प्रदर्शित दो मूल्यों का उल्लेख कीजिए।  
(b) किसी लटकते हुए 'गर्म' तार पर यदि पक्षी बैठ जाए तो उसे कोई हानि नहीं होती, किन्तु धरती पर उसको छूने से जान लेवा (घातक) धक्का लग सकता है। इसका क्या कारण है ?  
(c) विद्युत् संयंत्र से उत्पन्न विद्युत्-शक्ति को दूर स्थित उपभोक्ताओं तक पहुँचाने (संचरण) से पहले, उसकी वोल्टता को अति उच्च कर दिया जाता है। स्पष्ट कीजिए, क्यों।



During a thunderstorm the 'live' wire of the transmission line fell down on the ground from the poles in the street. A group of boys, who passed through, noticed it and some of them wanted to place the wire by the side. As they were approaching the wire and trying to lift the cable, Anuj noticed it and immediately pushed them away, thus preventing them from touching the live wire. During pushing some of them got hurt. Anuj took them to a doctor to get them medical aid.

Based on the above paragraph, answer the following questions :

- Write the two values which Anuj displayed during the incident.
- Why is it that a bird can sit on a suspended 'live' wire without any harm whereas touching it on the ground can give a fatal shock ?
- The electric power from a power plant is set up to a very high voltage before transmitting it to distant consumers. Explain, why.

### खण्ड य

### SECTION E

24. अनन्त लम्बाई के दो समान्तर तारों '1' तथा '2' से क्रमशः  $I_1$  तथा  $I_2$  अपरिवर्ती धारा प्रवाहित हो रही है। यदि दोनों धाराएँ एक ही दिशा में प्रवाहित हो रही हैं और दोनों तारों के बीच की दूरी  $d$  है, तो तार '1' के कारण तार '2' पर आरोपित चुम्बकीय क्षेत्र  $\vec{B}$  के लिए व्यंजक प्राप्त कीजिए। इससे एक उपयुक्त आरेख की सहायता से तार '1' के कारण तार '2' की एकांक (इकाई) लम्बाई पर लगने वाले बल का मान (परिमाण) तथा उसकी दिशा ज्ञात कीजिए। यदि दोनों तारों में विद्युत् धारा विपरीत दिशाओं में हो, तो इस बल की प्रकृति में किस प्रकार परिवर्तन होगा ? प्राप्त व्यंजक का उपयोग विद्युत् धारा के एस.आई. (S.I.) मात्रक को परिभाषित करने के लिए कीजिए।

5

### अथवा

किसी उच्चायी ट्रांसफॉर्मर की प्राथमिक तथा द्वितीयक कुंडलियों को लपेटने की व्यवस्था के लिए एक आवश्यक आरेख बनाइए। यह किस सिद्धान्त पर आधारित है ? किसी ट्रांसफॉर्मर में प्राथमिक तथा द्वितीयक कुंडलियों की वोल्टताओं के बीच एक सम्बन्ध, प्राथमिक तथा द्वितीयक कुंडलियों में तार के फेरों की संख्या के पदों में प्राप्त कीजिए। उपर्युक्त सम्बन्ध को प्राप्त करने के लिए प्रयुक्त दो मुख्य परिकल्पनाओं का उल्लेख कीजिए।

वास्तविक ट्रांसफॉर्मरों में ऊर्जा क्षय के कोई दो कारणों का उल्लेख कीजिए।

5



Two infinitely long straight parallel wires, '1' and '2', carrying steady currents  $I_1$  and  $I_2$  in the same direction are separated by a distance  $d$ . Obtain the expression for the magnetic field  $\vec{B}$  due to the wire '1' acting on wire '2'. Hence find out, with the help of a suitable diagram, the magnitude and direction of this force per unit length on wire '2' due to wire '1'. How does the nature of this force change if the currents are in opposite direction? Use this expression to define the S.I. unit of current.

**OR**

Draw a necessary arrangement for winding of primary and secondary coils in a step-up transformer. State its underlying principle and derive the relation between the primary and secondary voltages in terms of number of primary and secondary turns. Mention the two basic assumptions used in obtaining the above relation.

State any two causes of energy loss in actual transformers.

25. (a) किरखोफ के नियमों को लिखिए तथा स्पष्ट कीजिए कि ये किस आधार पर तर्कसंगत हैं ।
- (b) दो सेलों के विद्युत्-वाहक बल (ई.एम.एफ.) क्रमशः  $E_1$  तथा  $E_2$  हैं और आन्तरिक प्रतिरोध क्रमशः  $r_1$  तथा  $r_2$  हैं । ये दोनों सेल समान्तर (पार्श्व) क्रम में जुड़े हैं । इन दोनों के समतुल्य एकल सेल के (i) विद्युत्-वाहक बल (ई.एम.एफ.) तथा (ii) आन्तरिक प्रतिरोध के लिए व्यंजक व्युत्पन्न कीजिए जो इस समायोजन को प्रतिस्थापित कर सके ।

5

**अथवा**

- (a) “किसी पृष्ठ में परिबद्ध (बन्द) आवेश  $+Q$  के कारण बाहर की ओर विद्युत् फ्लक्स, इस पृष्ठ के आकार तथा साइज़ (आमाप) पर निर्भर नहीं करता ।” इस कथन की पुष्टि के लिए दो कारण दीजिए ।



(b) दो सर्वसम वृत्ताकार पाशों '1' तथा '2' की त्रिज्याएँ  $R$  हैं। इनके रैखिक आवेश घनत्व क्रमशः  $-\lambda$  तथा  $+\lambda$  C/m हैं। इन दो पाशों को समाक्ष और इस प्रकार रखा गया है कि इनके केन्द्रों के बीच की दूरी  $R\sqrt{3}$  है। पाश '1' के केन्द्र पर नेट विद्युत्-क्षेत्र का परिमाण (मान) तथा दिशा ज्ञात कीजिए।

5

(a) State Kirchhoff's rules and explain on what basis they are justified.

(b) Two cells of emfs  $E_1$  and  $E_2$  and internal resistances  $r_1$  and  $r_2$  are connected in parallel. Derive the expression for the (i) emf and (ii) internal resistance of a single equivalent cell which can replace this combination.

**OR**

(a) "The outward electric flux due to charge  $+Q$  is independent of the shape and size of the surface which encloses it." Give two reasons to justify this statement.

(b) Two identical circular loops '1' and '2' of radius  $R$  each have linear charge densities  $-\lambda$  and  $+\lambda$  C/m respectively. The loops are placed coaxially with their centres  $R\sqrt{3}$  distance apart. Find the magnitude and direction of the net electric field at the centre of loop '1'.

26. (a) हाइगेन्स के सिद्धान्त के उपयोग से एक समतल तरंगग्र के सघन माध्यम से विरल माध्यम में संचरण को दर्शाइए। इससे दोनों माध्यमों में तरंगग्रों की चालों के बीच अनुपात ज्ञात कीजिए।

(b) (i) किसी पोलैराइड पर आपतित अध्रुवित प्रकाश रैखिकतः ध्रुवित (पोलैराइज़्ड) क्यों हो जाता है ?

(ii) जब अध्रुवित प्रकाश विरल माध्यम से सघन माध्यम में प्रवेश करता है, तो वह दो माध्यमों के अन्तरापृष्ठ पर परावर्तन से ध्रुवित हो जाता है। इस परिघटना के लिए ब्रूस्टर के नियम के व्यंजक को व्युत्पन्न कीजिए।

5

**अथवा**



एक उभयोत्तल लेंस के दोनों पृष्ठों की वक्रता त्रिज्याएँ समान ( $R$ ) हैं। इसके पारदर्शी पदार्थ (माध्यम) का अपवर्तनांक  $\mu_1$  है। इसे आरेख में दर्शाए गए अनुसार अपवर्तनांक  $\mu_2$  माध्यम के सम्पर्क में रखा गया है।

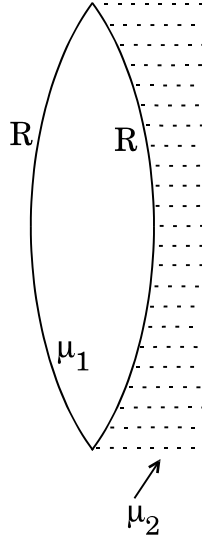

- इस संयोजन की तुल्य फोकस दूरी ज्ञात कीजिए।
- किस स्थिति में यह संयोजन अपसारी लेंस की भाँति कार्य करेगा ?
- जब एक वस्तु लेंस से बहुत दूर स्थित हो और  $\mu_1 > (\mu_2 + 1) / 2$  हो, तो इस स्थिति के लिए किरण आरेख बनाइए। इस संयोजन (व्यवस्था) द्वारा बने प्रतिबिम्ब की प्रकृति क्या होगी ?

5

- Use Huygens' principle to show the propagation of a plane wavefront from a denser medium to a rarer medium. Hence find the ratio of the speeds of wavefronts in the two media.
- Why does an unpolarised light incident on a polaroid get linearly polarised ?
  - Derive the expression of Brewster's law when unpolarised light passing from a rarer to a denser medium gets polarised on reflection at the interface.

**OR**

A biconvex lens with its two faces of equal radius of curvature  $R$  is made of a transparent medium of refractive index  $\mu_1$ . It is kept in contact with a medium of refractive index  $\mu_2$  as shown in the figure.

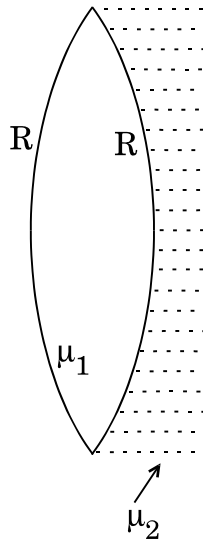

- (a) Find the equivalent focal length of the combination.
- (b) Obtain the condition when this combination acts as a diverging lens.
- (c) Draw the ray diagram for the case  $\mu_1 > (\mu_2 + 1) / 2$ , when the object is kept far away from the lens. Point out the nature of the image formed by the system.





**MARKING SCHEME**  
**SET 55/1/P**

No.	Expected Answer / Value Points	Marks	Total Marks
<b>Section A</b>			
-1, Q1 -2, Q5 -3, Q2	<p>The emf of a cell is equal to the terminal voltage when the circuit is open.</p> <p><b>Alternatively</b> The emf of a cell is greater than the terminal voltage when current is drawn through the cell.</p> <p><b>Alternatively</b> The emf of a cell is less than the terminal voltage when the cell is being charged.</p> <p><b>Alternatively</b>  <math>\varepsilon = V + ir</math>    <math>\varepsilon = V</math>    when <math>i = 0</math>  <math>\varepsilon &gt; V</math>    when <math>i &gt; 0</math>  <math>\varepsilon &lt; V</math>    when <math>i &lt; 0</math></p> <p><b>Alternatively</b> Emf of cell is work done by the cell force (of non-electrostatic origin) per unit charge, as charges are transferred through the cell.</p> <p>The terminal voltage is work done by the force of electric field per unit charge as charge move across the terminals of the cell through the external circuit.</p> <p>(Award this 1 mark if the student distinguishes between emf and terminal voltage in any one of the ways given above)</p>	<p>1</p> <p>or</p> <p>1</p> <p>or</p> <p>1</p> <p>or</p> <p>1</p> <p>or</p> <p>1</p>	<p>1</p>
-1, Q2 -2, Q4 -3, Q5	<p>The kinetic energy of a negative charge <u>decreases</u> in going from point B to point A in the given field configuration.</p> <p><b>Alternatively</b></p> <p>Decreases</p>	<p>1</p> <p>or</p> <p>1</p>	<p>1</p>
-1, Q3 -2, Q2 -3, Q4	<p>A repeater picks up a signal, amplifies it, and re transmits it, thereby extending the range of a communication system.</p> <p><b>Alternatively</b></p> <p>Amplifies and retransmits the signal.</p>	<p>1</p> <p>Or</p> <p>1</p>	<p>1</p>
t-1, Q4 -2, Q3 -3, Q1	<p>Concave Lens</p> <p><b>Alternatively</b></p> <p>It can be convex when the ambience is of higher refractive index. ( Award one mark if the student writes the lens as a convex lens and gives the reason for this)</p>	<p>1</p> <p>Or</p> <p>1</p>	<p>1</p>



-1, Q5  
-2, Q1  
-3, Q3

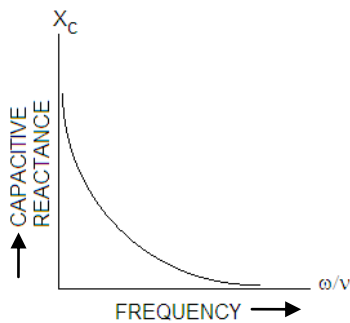

( Award 1/2 mark if the student just writes  $X_C = \frac{1}{\omega c}$  but does not draw the graph)

1

1

Section B

-1, Q6  
-2, Q7  
-3, Q10

Writing the two equations:	1/2 + 1/2
Values of R & S:	1/2 + 1/2

$$\frac{R}{S} = \frac{40}{60} \Rightarrow 3R = 2S \text{ -----(i)}$$

$$\frac{R+10}{S} = \frac{60}{40} \Rightarrow 2R + 20 = 3S \text{ -----(ii)}$$

Simultaneously solving the equations we get  
 $R = 8\Omega$       and       $S = 12\Omega$

1/2

1/2

1/2 + 1/2

-1, Q7  
-2, Q10  
-3, Q8

Writing $\mu = \frac{1}{\sin i_c}$	1/2
Calculating V	1/2
Writing Yes or Depends	1/2
Reason	1/2

$$i + e = A + D$$

$$\frac{3}{4}A + \frac{3}{4}D = A + D$$

$$D = \frac{1}{2}A = \frac{1}{2} \times 60^\circ = 30^\circ$$

Or

$$\mu = \frac{1}{\sin i_c} = \frac{1}{\sin 45^\circ} = \sqrt{2}$$

$$V = \frac{C}{\dots} = \frac{3 \times 10^8}{\dots} \text{ m/c}$$

1

1/2

1/2

1/2

1/2

2

	$= 2.1 \times 10^8 \text{ m/s}$ (also accept $V = \left(\frac{3}{\sqrt{2}}\right) \times 10^8 \text{ m/s}$ )  Yes (or Depends)  Reason: $\mu$ depends upon $\lambda$ , the wavelength of the incident light (or $\mu = A + \frac{B}{\lambda^2}$ )	1/2 1/2	2						
-1, Q8 -2, Q6 -3, Q9	<table border="1" style="width: 100%;"> <tr> <td>Writing <math>2\pi r = n\lambda</math></td> <td style="text-align: right;">1/2</td> </tr> <tr> <td>De Broglie formula <math>\lambda = \frac{h}{p}</math></td> <td style="text-align: right;">1/2</td> </tr> <tr> <td>Getting Bohr's second postulate</td> <td style="text-align: right;">1</td> </tr> </table> <p>For a stationary state <math>2\pi r = n\lambda</math> .....(i) 1/2</p> <p>By De-Broglie hypothesis wavelength of electron-wave is <math>\lambda = \frac{h}{p}</math> .....(ii) 1/2</p> <p>Equation (i) and (ii) give <math>rp = n \frac{h}{2\pi}</math> 1/2</p> <p>i.e. <math>l = \frac{nh}{2\pi}</math> (<math>\because l = pr</math>) which is Bohr's second postulate of quantization of angular momentum. 1/2</p>	Writing $2\pi r = n\lambda$	1/2	De Broglie formula $\lambda = \frac{h}{p}$	1/2	Getting Bohr's second postulate	1		2
Writing $2\pi r = n\lambda$	1/2								
De Broglie formula $\lambda = \frac{h}{p}$	1/2								
Getting Bohr's second postulate	1								
-1, Q9 -2, Q8 -3, Q7	<p>In ground wave communication, the e.m. wave glides over the earth's surface. 1</p> <p>At high frequencies, the rate of energy dissipation of the signal increases and the signal gets attenuated over a short distance. 1</p> <p style="text-align: center;">or</p> <p><b>Alternatively</b></p> <p>As the ground wave glides over the earth surface, its changing magnetic field induces an electric current, on the surface. 1</p> <p>At higher frequency the rate of variation (of magnetic field) is larger inducing a larger current, so energy dissipation of the signal is more. So the higher the frequency the more rapid is the signal alternation. 1</p>		2						
-1, Q10 -2, Q9 -3, Q6	<table border="1" style="width: 100%;"> <tr> <td>Photon: <math>h\nu = \frac{hc}{\lambda} = E</math></td> <td style="text-align: right;">1/2</td> </tr> <tr> <td>Electron: <math>\lambda = \frac{h}{p}</math></td> <td style="text-align: right;">1/2</td> </tr> <tr> <td>Calculating P</td> <td style="text-align: right;">1</td> </tr> </table> <p>Photon: <math>h\nu = E = \frac{hc}{\lambda}</math> or <math>\lambda = \frac{hc}{E}</math> 1/2</p> <p>Electron: <math>\lambda = \frac{h}{p}</math> 1/2</p>	Photon: $h\nu = \frac{hc}{\lambda} = E$	1/2	Electron: $\lambda = \frac{h}{p}$	1/2	Calculating P	1		
Photon: $h\nu = \frac{hc}{\lambda} = E$	1/2								
Electron: $\lambda = \frac{h}{p}$	1/2								
Calculating P	1								

## Section C

-1, Q11  
-2, Q20  
-3, Q15

Finding Equivalent Capacitance	2
Finding Charge	$\frac{1}{2}$
Finding Energy	$\frac{1}{2}$

The equivalent setup is

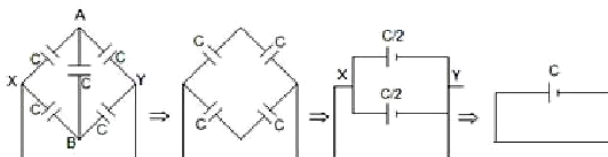

Here  $V_A = V_B$  (A & B are at the same potential) so the bridge capacitor can be removed.

(i)  $Q = CV = 6 \mu\text{C}$

(ii)  $U = \frac{1}{2}qV = 18 \mu\text{J}$

**NOTE:**

(i) In case the student gets an incorrect answer for the equivalent capacitance ( $C_{eq}$ ) but uses his/her calculated value of  $C_{eq}$  to correctly calculate the

(i) Charge and (ii) stored energy, award him/her  $\frac{1}{2} + \frac{1}{2}$  marks respectively.

(ii) If a student just writes the formulae  $q = C_{eq}V$  and

$u = \frac{1}{2}C_{eq}V^2$  but does not do the calculations, award him/her a total of  $\frac{1}{2}$  marks for the second part of the question.

2

$\frac{1}{2}$

$\frac{1}{2}$

3

-1, Q12  
-2, Q21  
-3, Q16

Principle	1
Two Factors	$\frac{1}{2} + \frac{1}{2}$
Reason for preference	1

Principle: The potential drop, across a part of a length  $l$  of a uniform wire of length  $L$  ( $L > l$ ), is proportional to the length  $l$ .

Two factors: (i) increasing the length  $L$  of the wire  
(ii) connecting a suitable resistance,  $R$ , in series with the potentiometer wire.

Reason: At the balance position, there is no net current drawn, from the cell and the cell is effectively in an open circuit condition.

This is not so for a voltmeter.

1

$\frac{1}{2}$

$\frac{1}{2}$

$\frac{1}{2}$

$\frac{1}{2}$

3

<p>-1, Q13 -2, Q22 -3, Q17</p>	<table border="1" style="width: 100%; border-collapse: collapse;"> <tbody> <tr> <td style="padding: 5px;">(a) Definition</td> <td style="text-align: right; padding: 5px;">1</td> </tr> <tr> <td style="padding: 5px;">(b) (i) Number of photons comparison</td> <td style="text-align: right; padding: 5px;">½</td> </tr> <tr> <td style="padding: 5px;">Reason</td> <td style="text-align: right; padding: 5px;">½</td> </tr> <tr> <td style="padding: 5px;">(iii) Maximum K.E.</td> <td style="text-align: right; padding: 5px;">½</td> </tr> <tr> <td style="padding: 5px;">Reason</td> <td style="text-align: right; padding: 5px;">½</td> </tr> </tbody> </table> <p>a) Intensity of radiation is determined by the number of photons incident per unit area per unit time. <span style="float: right;">1</span></p> <p>b) (i) Red Light <span style="float: right;">½</span> Reason: Energy of photon of red light is less than that of a photon of blue light <span style="float: right;">½</span> (Alternative <math>h\nu_{red} &lt; h\nu_{blue}</math>)</p> <p>(ii) Blue Light <span style="float: right;">½</span> Reason: Energy of photon of Blue light is more than that of a photon of red light <span style="float: right;">½</span> (Alternative <math>h\nu_{blue} &gt; h\nu_{red}</math>)</p> <p>Note: [If the student writes the Einstein's photoelectric equation: <math display="block">h\nu = h\nu_0 + \frac{1}{2}mv_{max}^2</math>Instead of the reason in part (ii) award him/her ½ mark only.]</p>	(a) Definition	1	(b) (i) Number of photons comparison	½	Reason	½	(iii) Maximum K.E.	½	Reason	½	3	
(a) Definition	1												
(b) (i) Number of photons comparison	½												
Reason	½												
(iii) Maximum K.E.	½												
Reason	½												
<p>-1, Q14 -2, Q16 -3, Q18</p>	<table border="1" style="width: 100%; border-collapse: collapse;"> <tbody> <tr> <td style="padding: 5px;">(a) Two reasons</td> <td style="text-align: right; padding: 5px;">½+½</td> </tr> <tr> <td style="padding: 5px;">(b) Writing mirror equation</td> <td style="text-align: right; padding: 5px;">½</td> </tr> <tr> <td style="padding: 5px;">(c) Proving the given result</td> <td style="text-align: right; padding: 5px;">1½</td> </tr> </tbody> </table> <p>Reasons: Reflecting telescopes can be made to have</p> <p>(i) Larger light gathering power <span style="float: right;">½</span></p> <p>(ii) Better resolution <span style="float: right;">½</span> (Also: less expensive; easier to design; free from aberrations) (any two)</p> <p><math>\frac{1}{v} + \frac{1}{u} = \frac{1}{f} \Rightarrow v = \frac{uf}{u-f}</math> .....(i) <span style="float: right;">½</span></p> <p>As 'u' is always -ve for a real object and 'f' is +ve for a convex mirror (as per Cartesian sign convention) <span style="float: right;">½</span></p> <p>∴ v is always +ve. <span style="float: right;">½</span></p> <p>Hence, the image is always on the other side of the mirror (and hence, virtual for all u) <span style="float: right;">½</span></p>	(a) Two reasons	½+½	(b) Writing mirror equation	½	(c) Proving the given result	1½	3					
(a) Two reasons	½+½												
(b) Writing mirror equation	½												
(c) Proving the given result	1½												
<p>-1, Q15 -2, Q17 -3, Q11</p>	<table border="1" style="width: 100%; border-collapse: collapse;"> <tbody> <tr> <td style="padding: 5px;">Statement of the law</td> <td style="text-align: right; padding: 5px;">1</td> </tr> <tr> <td style="padding: 5px;">Example</td> <td style="text-align: right; padding: 5px;">1</td> </tr> <tr> <td style="padding: 5px;">Numerical</td> <td style="text-align: right; padding: 5px;">1</td> </tr> </tbody> </table> <p>Lenz's law applies to closed circuit determining the direction of induced current states "The induced emf will appear in such a direction that it opposes</p>	Statement of the law	1	Example	1	Numerical	1	1					
Statement of the law	1												
Example	1												
Numerical	1												

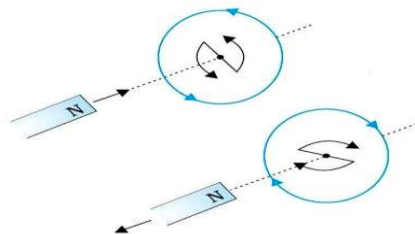

(Also accept any other example appropriate)

$$|\mathcal{E}| = L \frac{di}{dt}$$

$$|\mathcal{E}| = 5 \times 10^{-3} \times \frac{(4 - 1)}{30 \times 10^{-3}} V = 0.5V$$

**OR**

Difference and Explanation	1½
Formula	½
Calculation and result	1

In magnetism, Gauss's law states:  $\oint \vec{B} \cdot \vec{ds} = 0$

In electrostatics, Gauss's law states:  $\oint \vec{E} \cdot \vec{ds} = \frac{q}{\epsilon_0}$

Reason: Isolated magnetic poles do not exist

$$B = \frac{\mu_0}{4\pi} \left( \frac{m}{R^3} \right) = 10^{-7} \left( \frac{m}{R^3} \right)$$

$$m = \frac{0.4 \times 10^{-4} \times (6400 \times 10^3)^3}{10^{-7}}$$

$$= 1.1 \times 10^{23} \text{ Am}^2$$

-1, Q16  
-2, Q18  
-3, Q12

Production	½
Source of Energy	½
Schematic Sketch	½
Directions of $\vec{E}$ and $\vec{B}$ :	½+½
Relation	½

Production: Electromagnetic waves are produced by 'accelerated Charges'

The battery/ Electric field that accelerates the charge carriers is the source of

½

½

1

3

½

½

½

½

½.

½

3

½

½

Schematic sketch/ diagram

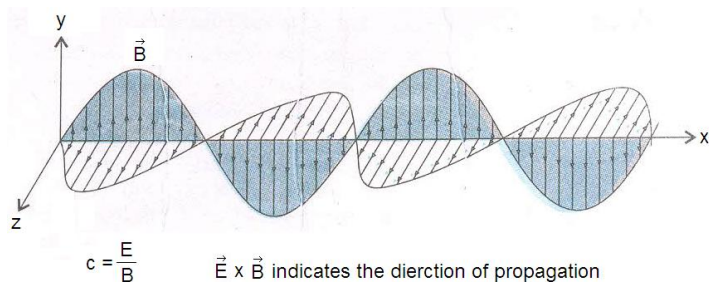

Directions of  $\vec{E}$  Along  $y$  axis/ Along  $z$  axis

Directions of  $B$  Along  $z$  axis/ Along  $y$  axis

Relation:  $c = \frac{E}{B}$

1/2

1/2

1/2

1/2

3

-1, Q17  
-2, Q19  
-3, Q13

Writing the formula: $N = N_0 e^{-\lambda t}$	1/2
Obtaining the Relation	1
Numerical	1 1/2

We have  $N = N_0 e^{-\lambda t}$

When  $t = T_{1/2}$  (the half life), we have  $N = \frac{N_0}{2}$

$$\therefore \frac{N_0}{2} = N_0 e^{-\lambda T_{1/2}}$$

This gives

$$T_{1/2} = \frac{\ln_e 2}{\lambda}$$

Numerical: We have  $\frac{N}{N_0} = 6.25\% = \frac{6.25}{100} = \frac{1}{16} = \left(\frac{1}{2}\right)^4$

$\therefore$  Required time =  $4 \times$  (half life)

=  $4 \times 100$  days

= 400 days

1/2

1/2

1/2

1/2

1/2

1/2

3

-1, Q18  
-2, Q11  
-3, Q14.

Two important considerations	1/2+1/2
Circuit Diagram	1/2
Principle	1/2
Working	1

Two important considerations

Heavy doping of both p and n sides

1/2



(Award 1/2 mark even if the student writes only one of these)

Circuit diagram

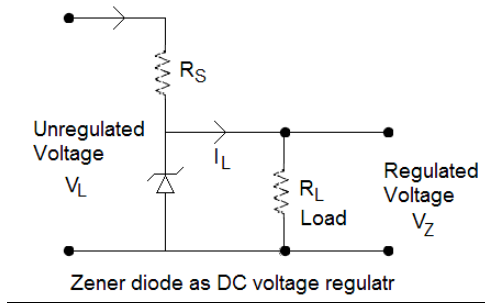

1/2

Principle: Even small reverse bias voltage (5V) can produce a very high electric field because the depletion region is very thin

1/2

Working - The unregulated DC voltage is connected to the Zener diode through a series resistance  $R_S$  such that the Zener diode is reverse biased. In break down region, the Zener voltage remains constant even though the current through Zener diode changes. This helps to regulate the output voltage

1

3

-1, Q19  
-2, Q12  
-3, Q21

Energy band diagrams	1 1/2
Effect of change of temperature	1 1/2

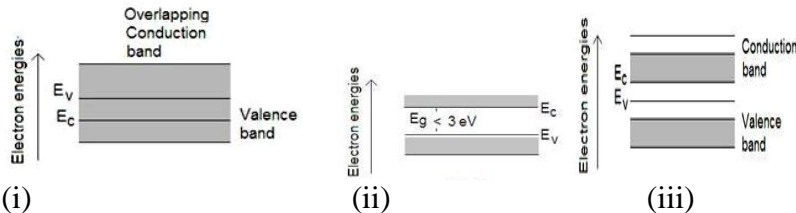

1/2+1/2+1/2

(i) In conductor, collision become more frequent at higher temperature lowering conductivity.

1/2

(ii) In semiconductors, more electron hole pairs become available at higher temperature so conductivity increases.

1/2

(iii) In insulators, the band gap is unsurpassable for ordinary temperature rise. Hence there is practically no change in their behavior.

1/2

3

-1, Q20  
-2, Q13  
-3, Q22

(a) Three Basic units & their function	1/2+1/2+1/2
(b) Three applications of Internet	1/2+1/2+1/2

Three Basic units  
Transmitter:

1/2

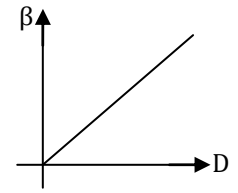

	<p>Communication channel: The link for propagating the signal from transmitter to receiver.</p> <p>Receiver: Extracting the message signal from the signal received by it.</p> <p>Three applications of internet:</p> <p>(i) internet surfing (ii) E-mails (iii) E-banking (iv) E-shopping (v) E-booking (e-ticketing) (vi) Social networking + additional applications(Any three)</p>	<p>1/2</p> <p>1/2</p> <p>1/2 + 1/2 + 1/2</p>	<p>3</p>										
<p>-1, Q21 -2, Q14 -3, Q19</p>	<table border="1"> <tr> <td>(a) Conditions</td> <td>1/2</td> </tr> <tr> <td>(b) Formula</td> <td>1/2</td> </tr> <tr> <td>Graph</td> <td>1</td> </tr> <tr> <td>Effect on Fringe Width</td> <td>1/2</td> </tr> <tr> <td>Information from scope</td> <td>1/2</td> </tr> </table>	(a) Conditions	1/2	(b) Formula	1/2	Graph	1	Effect on Fringe Width	1/2	Information from scope	1/2		
(a) Conditions	1/2												
(b) Formula	1/2												
Graph	1												
Effect on Fringe Width	1/2												
Information from scope	1/2												
	<p><u>Conditions:</u> The two superposing sources must be coherent and obtained from the same source. (Also award this 1/2 mark is the student just writes that two sources must have the same frequency)</p> <p><u>Formula:</u> <math>\beta = \frac{\lambda D}{d}</math></p>  <p>Slope = <math>\frac{\lambda}{d}</math> or <math>\lambda = slope \times d</math></p> <p>Effect: the fringe width would increase (Alternatively : <math>\beta \propto \frac{1}{d}</math>)</p>	<p>1/2</p> <p>1/2</p> <p>1</p> <p>1/2</p> <p>1/2</p>											

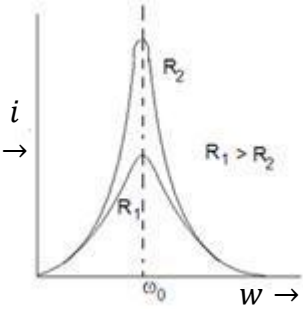

t-1, Q22 -2, Q15 -3, Q20	<table border="1"> <tr> <td>Graph</td> <td>1</td> </tr> <tr> <td>(a) Sharper resonance (Case + reason)</td> <td><math>\frac{1}{2} + \frac{1}{2}</math></td> </tr> <tr> <td>(b) More power Dissipation case</td> <td><math>\frac{1}{2}</math></td> </tr> <tr> <td>Reason</td> <td><math>\frac{1}{2}</math></td> </tr> </table>  <p>(a) Sharper for <math>R = R_2</math>          Sharpness of resonance = <math>\frac{\omega_0 L}{R} \propto \frac{1}{R}</math></p> <p>(b) More power dissipation for <math>R = R_2</math>          At Resonance, power dissipation = <math>\frac{V^2}{R} \propto \frac{1}{R}</math> (for same V)</p>	Graph	1	(a) Sharper resonance (Case + reason)	$\frac{1}{2} + \frac{1}{2}$	(b) More power Dissipation case	$\frac{1}{2}$	Reason	$\frac{1}{2}$	1   $\frac{1}{2}$ $\frac{1}{2}$  $\frac{1}{2}$ $\frac{1}{2}$	3
Graph	1										
(a) Sharper resonance (Case + reason)	$\frac{1}{2} + \frac{1}{2}$										
(b) More power Dissipation case	$\frac{1}{2}$										
Reason	$\frac{1}{2}$										

Section D

-1, Q23 -2, Q23 -3, Q23	<table border="1"> <tr> <td>(a) Values</td> <td>1+1</td> </tr> <tr> <td>(b) Reason</td> <td>1</td> </tr> <tr> <td>(c) Explanation</td> <td>1</td> </tr> </table> <p>(a) Presence of mind, careful, helpful/Awareness etc. (any two). <span style="float: right;"><math>\frac{1}{2} + \frac{1}{2}</math></span></p> <p>(b) The two feet of the bird, sitting on the live wire, are at the same potential. Hence, no current passes through its body. <span style="float: right;"><math>\frac{1}{2}</math></span></p> <p>The potential difference between the earth and the live wire when somebody touches a live wire, standing on the ground can result in a passage of current, so a fatal shock. <span style="float: right;">1</span></p> <p>(c) Transmitting the power at a very high voltage is equivalent to lowering the current to a very low level, so <span style="float: right;"><math>\frac{1}{2}</math></span>          Transmission losses (<math>= i^2 R</math>) are minimized. <span style="float: right;"><math>\frac{1}{2}</math></span></p>	(a) Values	1+1	(b) Reason	1	(c) Explanation	1	          	4
(a) Values	1+1								
(b) Reason	1								
(c) Explanation	1								

Section E

-1, Q24 -2, Q26 -3, Q25	<table border="1"> <tr> <td>Obtaining the expression for magnetic field</td> <td>2</td> </tr> <tr> <td>Diagram &amp; Force (magnitude &amp; direction)</td> <td><math>\frac{1}{2} + \frac{1}{2} + \frac{1}{2}</math></td> </tr> <tr> <td>Change in nature of force</td> <td><math>\frac{1}{2}</math></td> </tr> </table>	Obtaining the expression for magnetic field	2	Diagram & Force (magnitude & direction)	$\frac{1}{2} + \frac{1}{2} + \frac{1}{2}$	Change in nature of force	$\frac{1}{2}$		
Obtaining the expression for magnetic field	2								
Diagram & Force (magnitude & direction)	$\frac{1}{2} + \frac{1}{2} + \frac{1}{2}$								
Change in nature of force	$\frac{1}{2}$								

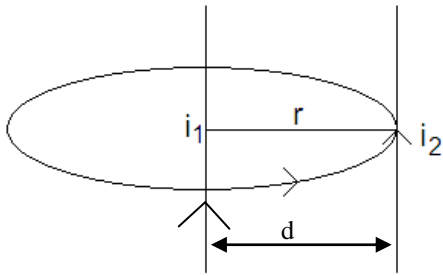

1/2

Consider a (circle) Amperian loop of radius 'd' centered at the wire 'i' and having its plane perpendicular to the wire.

$$\oint \vec{B} \cdot d\vec{l} = \mu_0 i_1$$

1/2

By symmetry B has the same magnitude at every point on the contour, and is tangential. If we go along the contour anticlockwise,  $\vec{B}$  is along  $d\vec{l}$  and  $\vec{B} \cdot d\vec{l} = Bdl$

1/2

$$B \oint dl = \mu_0 i, \quad B 2\pi d = \mu_0 i_1$$

1/2

$$\therefore B_i = \frac{\mu_0 i_1}{2\pi d}$$

1/2

Now  $\vec{F}_{2i} = i_2 \vec{l}_2 \times \vec{B}_i$   $\therefore$

$$F_{2i} = i_2 l_2 B = \frac{\mu_0 i_1 i_2 l_2}{2\pi d} \quad (\text{substituting the value of } B)$$

$$\therefore \frac{\text{Force}}{\text{Length}} = \frac{\mu_0 i_1 i_2}{2\pi d}$$

1/2

$\vec{F}$  is directed towards left so wire '2' is attracted by the force of magnetic field of wire '1', acting on it.

1/2

If I, reverses direction,  $\vec{F}$  is directed toward right i.e. wire 1 repels wire 2`.

$$\text{If } i_1 = i_2 = 1 \text{ amp and } d = 1\text{m then } \frac{F}{l} = \frac{\mu_0}{2\pi} \text{ N/m}$$

$$= 2 \times 10^{-7} \text{ N/m}$$

1

Definition of SI unit of current

Or

5

Diagram	1/2
Principle	1/2
Deriving the relation	2
Two assumption	1/2+1/2
Two causes of energy loss	1/2+1/2

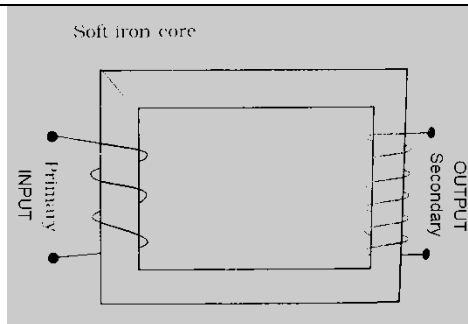

Principle : A transformer is based on the phenomena of mutual induction, i.e., whenever the current flowing in the primary coil changes, an emf is induced in the secondary coil.

Let  $\frac{d\phi}{dt}$  be the rate of change of magnetic flux per turn of each coil

$\therefore$  emf induced in the primary

$$E_p = N_p \frac{d\phi}{dt}$$

emf in secondary

$$E_s = N_s \frac{d\phi}{dt}$$

$N_p$  &  $N_s$  are the no. of turns in primary & secondary coils respectively.

$$\therefore \frac{E_s}{E_p} = \frac{E_s}{E} = \frac{N_s}{N_p}$$

Assumptions

- (i) The flux linked ( $=\phi$ ) with each turn of primary and secondary coils, has the same value.
- (ii) Induced EMF in primary = applied A/c, Voltage across it.
- (iii) The primary resistance and current are small.
- (iv) There is no leakage of magnetic flux. The same magnetic flux links both, primary & secondary coils.
- (v) The secondary current is small.

**(Any two of the above assumptions)**

Energy losses are due to

- (i) Flux leakage/ Eddy current/ Humming sound/ Heat loss ( $I^2R$ )
- (ii) Hysteresis loss

**(Any Two)**

- (a) Two rules & Justification
- (b) Deriving the expression

1+1  
2+1

1/2

1/2

1/2

1/2

1/2

1/2

1/2+1/2

1/2+1/2

5

-1, Q25  
-2, Q24  
-3, Q26



junction is equal to the sum to currents leaving the junction. This rule is based on the law of conservation of charge.

1/2

(ii) The loop rule: The algebraic sum of the changes in potentials in any loop is equal to the algebraic sum of emfs.

1/2

$$\sum iR = \sum E_i$$

The basis of this rule is the law of conservation of energy for electric circuits.

1/2

2

(b)

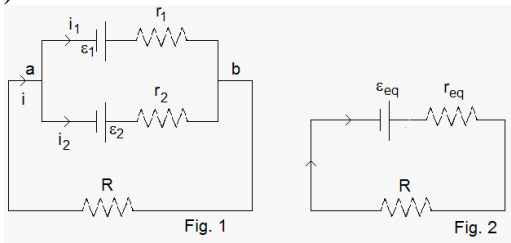

At junction a  $i = i_1 + i_2$  ..... (i)

1/2

For the two loops involving R and  $r_1$  and R &  $r_2$

$$iR + i_1 r_1 = \varepsilon_1 \quad \text{..... (ii)}$$

1/2

$$iR + i_2 r_2 = \varepsilon_2 \quad \text{..... (iii)}$$

1/2

solving (i) , (ii) and (iii) simultaneously we get

1/2

$$iR + \frac{r_1 r_2}{r_1 + r_2} = \frac{\varepsilon_1 r_2 + \varepsilon_2 r_1}{r_1 + r_2} \quad \text{..... (iv)}$$

Fig, (ii) shows the equivalent circuit, giving the equation

$$iR + i r_{eq} = \varepsilon_{eq} \quad \text{..... (v)}$$

Comparing equation (iv) and (v) we have

$$r_{eq} = \frac{r_1 r_2}{r_1 + r_2}; \quad \varepsilon_{eq} = \frac{\varepsilon_1 r_2 + \varepsilon_2 r_1}{r_1 + r_2}$$

1/2+1/2

3

Or

5

a) Two reasons	1+1
b) Finding the Net Electric Field	3

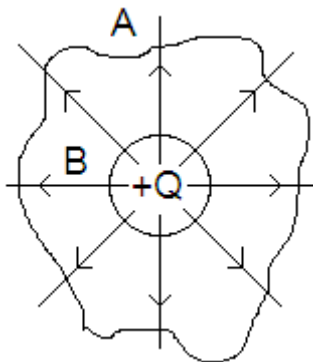

The figure shows two surfaces A and B of different shapes and sizes enclosing a given charge  $+Q$ .

(i) For a given charge, the number of field lines, emanating from it, depends only on the net charge enclosed and not on the shape or size of surface enclosing it.

(ii) By Gauss's law of electrostatics, the outward flux of the electric field is the  $\oint \vec{E} \cdot d\vec{s} = \frac{Q}{\epsilon_0}$ . This is same for both the surfaces, since both enclose the same charge ( $Q$ ).

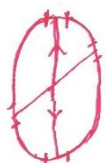

(b) Field of the centre of loop 1, due to its own charge = zero  
(This is because each element of the loop, has a corresponding symmetrical element which produces an equal and opposite fields at the centre)

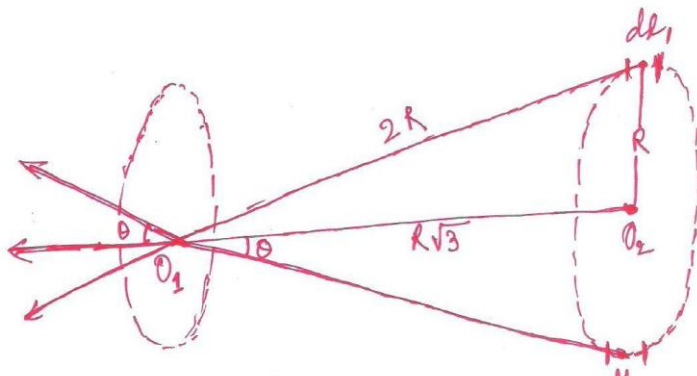

1

1

1

1/2

5

For finding the field at  $O_1$ , due to coil 2

Total field at  $O_1$  due to two elements  $dl_1$  and  $dl_2$  of coil 2.

= sum of their horizontal components

$$= \frac{1}{4\pi\epsilon_0} \cdot \frac{2\lambda dl}{(2R)^2} \cos\theta = \frac{1}{4\pi\epsilon_0} \cdot \frac{2\lambda dl}{(2R)^2} \cdot \frac{R\sqrt{3}}{R}$$

$$\frac{1}{4\pi\epsilon_0} \cdot \frac{2\lambda dl}{(2R)^2} \cdot \frac{\sqrt{3}}{2}$$

$$\therefore \text{Total field at } O_1 = \frac{\sqrt{3}}{4\pi\epsilon_0} \cdot \frac{\lambda}{4R^2} \cdot (\sum dl)_{\text{over half the loop}}$$

$$= \frac{\sqrt{3}}{4\pi\epsilon_0} \cdot \frac{\lambda}{4R^2} \cdot \pi R$$

$$= \frac{1}{4\pi\epsilon_0} \cdot \frac{\sqrt{3}\pi\lambda}{4R} = \frac{\sqrt{3}\pi\lambda}{16\epsilon_0 R}$$

This field, as seen from above, is directed along the line  $O_2 O_1$ .

$$\therefore \text{Total field at } O_1 \text{ due to both the coils } O_1 = \frac{1}{4\pi\epsilon_0} \left[ \frac{(\pi\sqrt{3})\lambda}{4R} \right] \text{ (along } O_2 O_1)$$

**Alternatively**

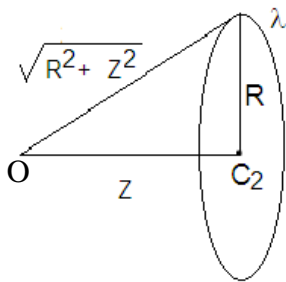

The field at an axial point of a circular loop of radius  $R$  and linear charge density  $\lambda$ , is given by

$$\vec{E} = \frac{\lambda R}{2\epsilon_0} \frac{Z}{(R^2 + Z^2)^{3/2}} \hat{z}$$

The field at  $C$

$$\text{is } \vec{E} = \vec{E}_1 + \vec{E}_2 = 0 + \frac{\lambda R}{2\epsilon_0} \frac{R\sqrt{3}}{(2R)^3} \text{ towards left}$$

$$= \frac{\lambda\sqrt{3}}{16\epsilon_0 R} \text{ towards left.}$$

$$(\vec{E}_1 = 0 \text{ since } z = 0)$$

1/2

1/2

1/2

3

5

1

1/2

1/2

1/2

1/2



( $\vec{E}_2$  is towards left because  $\lambda$  is (+)ve)

-1, Q26  
-2, Q25  
-3, Q24

(a) Diagram	1
Proving $\frac{v_2}{v_1} = \frac{\sin i}{\sin r}$	2
(b) (i) Reason	1
(ii) Brewster law	1

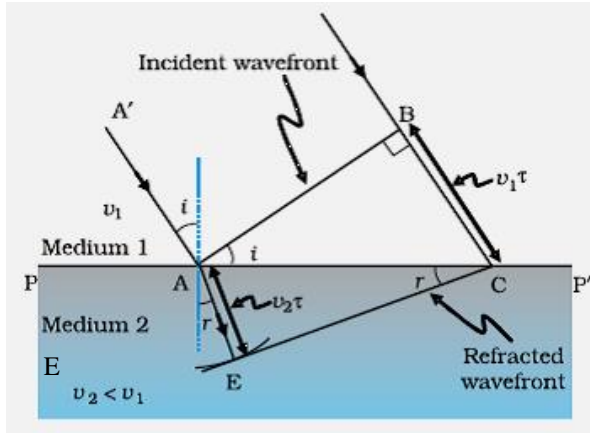

(a) We consider refraction of a plane wave at a rarer medium, i.e.,  $v_1 > v_2$   
The angle of refraction will be greater than angle of incidence.

$$n_1 \sin i = n_2 \sin r$$

$$\sin i_c = \frac{n_2}{n_1}$$

$$\therefore \frac{n_2}{n_1} = \frac{\sin i}{\sin r}$$

But  $\frac{n_2}{n_1} = \text{ratio of speed of lights}$

$$\therefore \frac{v_2}{v_1} = \frac{\sin i}{\sin r}$$

(i) It absorbs the electric vectors of the incident light along the direction of alignment of its molecules and only lets the perpendicular electric vectors to go through.

(ii) At the Brewster's angle of incidence ( $\angle i_B$ )

$$\angle i_B + \angle r_B = \frac{\pi}{2}$$

1

1/2

1/2

2

1

1/2

1/2



$$\therefore \mu = \frac{\sin i_B}{\sin r_B} = \tan i_B \left( \frac{1}{2} \right)$$

This is known as Brewsters's Law.

Or

Equivalent Focal Length	2½
Obtaining the condition	1
Nature of combination + Ray diagram	1
Nature of image	½

The image distance  $V_1$  for the surface is the object distance for the second surface, Radius of curvature of the first surface is  $R$  that of the second surface is  $-R$

$$\frac{\mu_1}{V_1} - \frac{1}{u} = \frac{\mu_1 - 1}{R} \quad (\text{Refraction at first surface})$$

$$\frac{\mu_2}{V} - \frac{\mu_1}{V_1} = \frac{\mu_2 - \mu_1}{-R} \quad (\text{Refraction at second surface})$$

$$\therefore \frac{\mu_2}{V} - \frac{1}{u} = \frac{2\mu_1 - \mu_2 - 1}{R}$$

At  $u = -\infty$        $V = f$

$$\therefore f = \frac{\mu_2 R}{2\mu_1 - \mu_2 - 1}$$

(b) For the combination to be diverging  
 $f < 0$

This requires  $\mu_1 < \left( \frac{\mu_2 + 1}{2} \right)$

(c) for  $\mu_1 > \frac{\mu_2 + 1}{2}$ ,  $f > 0$

So the combination acts as a converging lens

(of focal length  $f = \frac{\mu_2 R}{2\mu_1 - \mu_2 - 1}$ ).

½

½

2

½

5

½



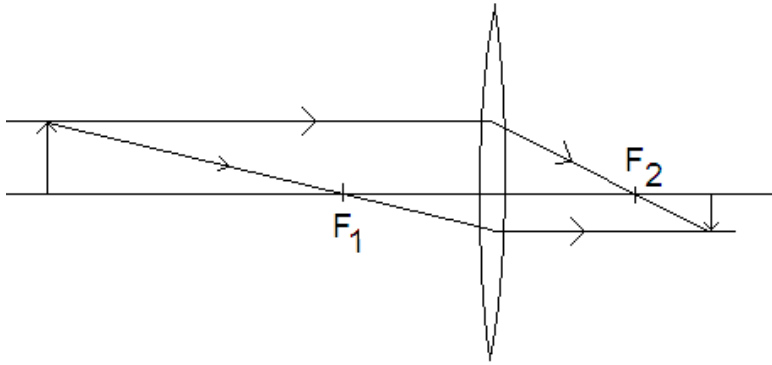

$\frac{1}{2}$

5

The image formed is a real image.

